

One meter channel

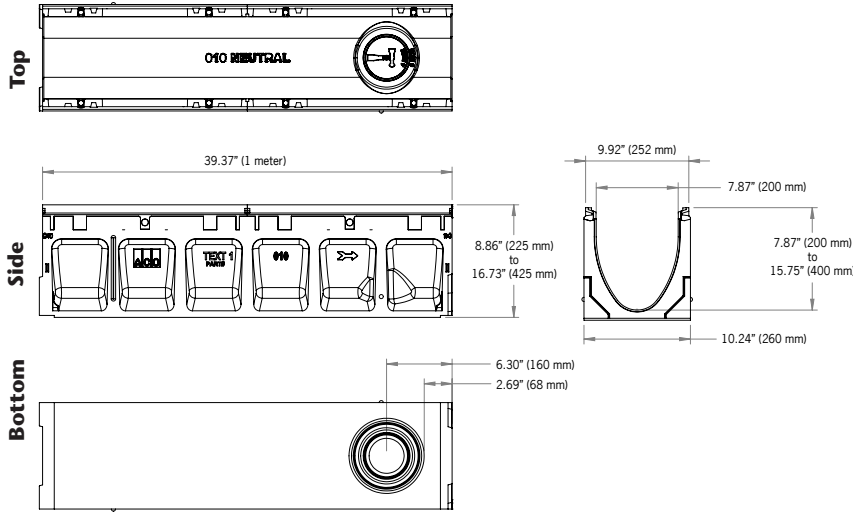

Knock-outs included on every 5th channel

Half meter channel

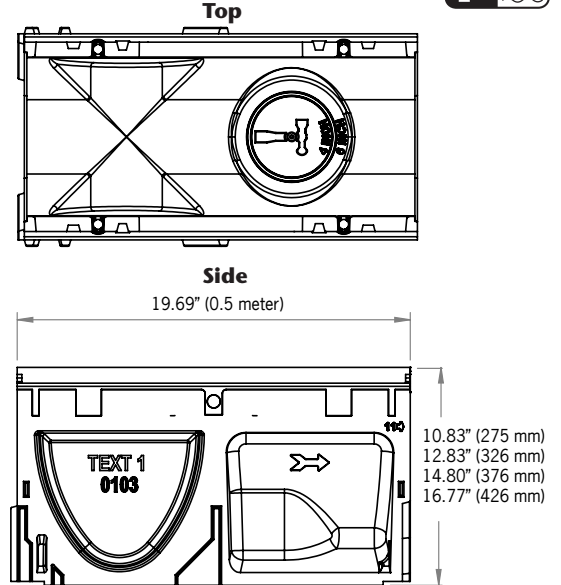

Type 902D In-line catch basin

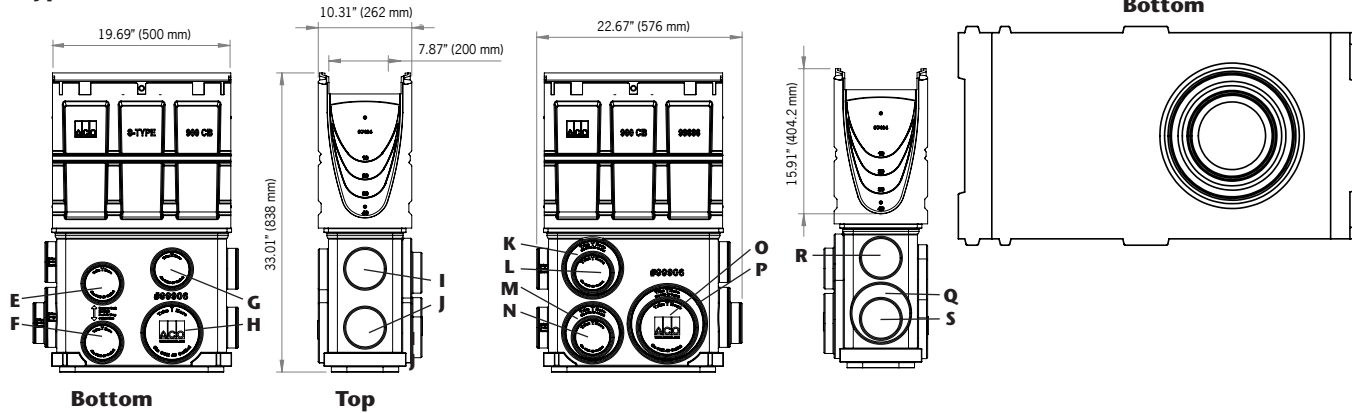

Total capacity = 19 gallons

Outlet flow rates

Outlet	Product	Outlet size (Sch. 40)	Invert Depth	GPM	CFS
A	Bottom outlet - SK2-00	4" round	7.87"	153	0.34
A	Bottom outlet - SK2-040	4" round	15.75"	216	0.48
B	Bottom outlet - SK2-00	6" round	7.87"	344	0.77
B	Bottom outlet - SK2-040	6" round	15.75"	486	1.08
C	End outlet - SK2-00	4" round	7.87"	132	0.29
C	End outlet - SK2-40	4" round	15.75"	202	0.45
D	End outlet - SK2-10	6" round	9.84"	320	0.71
D	End outlet - SK2-40	6" round	15.75"	437	0.97
E	Type SK2-902D	4" round	25.33"	263	0.59
F	Type SK2-902D	4" round	31.83"	297	0.66
G	Type SK2-902D	4" round	23.76"	254	0.57
H	Type SK2-902D	6" round	31.83"	658	1.47
I	Type SK2-902D	4" round	23.91"	255	0.57
J	Type SK2-902D	4" round	30.40"	290	0.65
K	Type SK2-902D	6" round	24.68"	570	1.27
L	Type SK2-902D	4" round	24.13"	256	0.57
M	Type SK2-902D	6" round	31.82"	658	1.47
N	Type SK2-902D	4" round	31.26"	294	0.66
O	Type SK2-902D	6" round	31.26"	651	1.45
P	Type SK2-902D	8" round	31.82"	1149	2.56
Q	Type SK2-902D	6" round	30.32"	640	1.43
R	Type SK2-902D	4" round	23.19"	251	0.56
S	Type SK2-902D	4" round	29.90"	288	0.64

Note: These are the pipe flow rates at the specified outlet, NOT channel flow rates. *Catch basin flow rates are without trash bucket - using trash bucket reduces flow.

End Cap

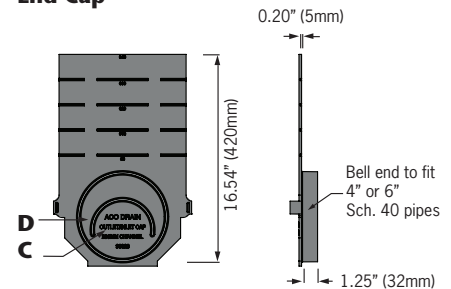

Supplied By:

TRENCHDRAIN SUPPLY

877-903-7246

www.trenchdrainsupply.com



PowerDrain - S200K iron edged channels



ACO Specification Information

Description	Part No.	Invert Inches ²	mm ²	Weight lbs.	Description	Part No.	Invert Inches ²	mm ²	Weight lbs.
SK2-00 Neutral channel - 39.37" (1m)^D	68041	7.87	200	96.3	SK2-28 Sloped channel - 39.37" (1m)	68028	13.38	340	129.1
SK2-1 Sloped channel - 39.37" (1m)	68001	8.07	205	97.4	SK2-29 Sloped channel - 39.37" (1m)	68029	13.58	345	130.3
SK2-2 Sloped channel - 39.37" (1m)	68002	8.26	210	98.6	SK2-30 Sloped channel - 39.37" (1m) ^D	68030	13.77	350	131.4
SK2-3 Sloped channel - 39.37" (1m)	68003	8.46	215	99.8	SK2-030 Neutral channel - 39.37" (1m)^D	68047	13.77	350	131.9
SK2-4 Sloped channel - 39.37" (1m)	68004	8.66	220	101.0	SK2-0303 Neutral channel - 19.69" (0.5m)^D	68048	13.77	350	65.8
SK2-5 Sloped channel - 39.37" (1m) ^D	68005	8.85	225	102.1	SK2-31 Sloped channel - 39.37" (1m)	68031	13.97	355	132.6
SK2-6 Sloped channel - 39.37" (1m)	68006	9.05	230	103.3	SK2-32 Sloped channel - 39.37" (1m)	68032	14.17	360	133.8
SK2-7 Sloped channel - 39.37" (1m)	68007	9.25	235	104.5	SK2-33 Sloped channel - 39.37" (1m)	68033	14.37	365	135.0
SK2-8 Sloped channel - 39.37" (1m)	68008	9.44	240	105.7	SK2-34 Sloped channel - 39.37" (1m)	68034	14.56	370	136.1
SK2-9 Sloped channel - 39.37" (1m)	68009	9.64	245	106.8	SK2-35 Sloped channel - 39.37" (1m) ^D	68035	14.76	375	137.3
SK2-10 Sloped channel - 39.37" (1m) ^D	68010	9.84	250	108.0	SK2-36 Sloped channel - 39.37" (1m)	68036	14.96	380	138.5
SK2-010 Neutral channel - 39.37" (1m)^D	68043	9.84	250	108.4	SK2-37 Sloped channel - 39.37" (1m)	68037	15.15	385	139.7
SK2-0103 Neutral channel - 19.69" (0.5m)^D	68044	9.84	250	54.2	SK2-38 Sloped channel - 39.37" (1m)	68038	15.35	390	140.8
SK2-11 Sloped channel - 39.37" (1m)	68011	10.03	255	109.2	SK2-39 Sloped channel - 39.37" (1m)	68039	15.55	395	142.0
SK2-12 Sloped channel - 39.37" (1m)	68012	10.23	260	110.3	SK2-40 Sloped channel - 39.37" (1m) ^D	68040	15.74	400	143.2
SK2-13 Sloped channel - 39.37" (1m)	68013	10.43	265	111.5	SK2-040 Neutral channel - 39.37" (1m)^D	68049	15.74	400	143.5
SK2-14 Sloped channel - 39.37" (1m)	68014	10.62	270	112.7	SK2-0403 Neutral channel - 19.69" (0.5m)^D	68050	15.74	400	71.8
SK2-15 Sloped channel - 39.37" (1m) ^D	68015	10.82	275	113.9	SK2-903D In-line catch basin - 19.69" (0.5m) ^D	68053	37.36	949	81.8
SK2-16 Sloped channel - 39.37" (1m)	68016	11.02	280	115.0	SK2-904D In-line catch basin - 19.69" (0.5m) ^D	68055	49.41	1255	116.0
SK2-17 Sloped channel - 39.37" (1m)	68017	11.22	285	116.2	SK2-631D catch basin - 19.69" (0.5m) ^D	68056	49.41	1255	126.0
SK2-18 Sloped channel - 39.37" (1m)	68018	11.41	290	117.4	Series 600 Optional plastic riser	99902	-	-	10.0
SK2-19 Sloped channel - 39.37" (1m)	68019	11.61	295	118.5	Foul air trap - fits both 910 & 610 basins	90854	-	-	1.2
SK2-20 Sloped channel - 39.37" (1m) ^D	68020	11.81	300	119.7	SK2 channel Universal end cap	96823	19.69	500	1.4
SK2-020 Neutral channel - 39.37" (1m)^D	68045	11.81	300	120.0	Debris strainer for 4" bottom knockout	93488	-	-	0.2
SK2-0203 Neutral channel - 19.69" (0.5m)^D	68046	11.81	300	60.0	8" channel Installation device	97478	-	-	4.0
SK2-21 Sloped channel - 39.37" (1m)	68021	12.00	305	120.9	Grate removal tool	01318	-	-	0.3
SK2-22 Sloped channel - 39.37" (1m)	68022	12.20	310	122.1	SK2 ductile iron slotted grate [®]	02449	-	-	30.8
SK2-23 Sloped channel - 39.37" (1m)	68023	12.40	315	123.2	SK2 ductile iron longitudinal grate [®]	72263	-	-	26.4
SK2-24 Sloped channel - 39.37" (1m)	68024	12.59	320	124.4					
SK2-25 Sloped channel - 39.37" (1m) ^D	68025	12.79	325	125.6					
SK2-26 Sloped channel - 39.37" (1m)	68026	12.99	330	126.8					
SK2-27 Sloped channel - 39.37" (1m)	68027	13.18	335	127.9					

Notes:

1. This channel offers bottom knockout feature: 6" & 8" round.
2. Inverts shown are male end; for female invert depth subtract 5mm (≈0.2") from male invert (except neutral channels where it will be same as male invert). To calculate overall channel depth, add 25.4mm (1.0") to invert depth.
3. Catch basin assembly includes polymer concrete top, trash bucket and plastic base.
4. Catch basin assembly includes polymer concrete top, deep trash bucket, plastic riser and plastic base.
5. Water intake per meter channel is 134.2 in² (865.80 cm²).
6. See 8" width ductile iron grate specification info for grate details.

Specifications		Frost proof	YES	edge rail shall be at least 1/4" (6mm) thick.
		Salt proof	YES	
		Dilute acid and alkali resistant	YES	
General				
The surface drainage system shall be ACO Drain PowerDrain S200K as manufactured by ACO Polymer Products, Inc. or equal approved. (Add appropriate grate - see grate spec information).		The nominal clear opening shall be 8" (200mm) with overall width of 10.24" (260mm). Pre-cast units shall be manufactured with either an invert slope of 0.5% or with neutral invert and have a wall thickness of at least 0.67" (16mm). Each unit will feature a partial radius in the trench bottom and a male to female interconnecting end profile. Units shall have horizontal cast in anchoring keys on the outside wall to ensure maximum mechanical bond to the surrounding bedding material and pavement surface. The ductile iron edge rail will be integrally cast in by the manufacturer to ensure maximum homogeneity between polymer concrete body and edge rail. Each		
Materials		Installation		
The trench system bodies shall be manufactured from polymer concrete with minimum properties as follows:		The trench drain system shall be installed in accordance with the manufacturer's installation instructions and recommendations.		
Compressive strength:	14,000 psi			
Flexural strength:	4,000 psi			
Water absorption	0.07%			

ACO Polymer Products, Inc.

Northeast Sales Office
9470 Pinecone Dr.
Mentor, OH 44060
Tel: (440) 639-7230
Toll free: (800) 543-4764
Fax: (440) 639-7235

West Sales Office
825 W. Beechcraft St.
Casa Grande, AZ 85122
Tel: (520) 421-9988
Toll Free: (888) 490-9552
Fax: (520) 421-9899

Southeast Sales Office
4211 Pleasant Road
Fort Mill, SC 29708
Toll free: (800) 543-4764
Fax: (803) 802-1063



Electronic Contact:
info@ACODrain.us
www.ACODrain.us



© Feb 11, 2016 ACO Polymer Products, Inc. This information is believed to be accurate but it is not guaranteed to be so. We cannot assume liability for results that buyer obtains with our product since conditions of use are beyond the control of the company. It is the customer's responsibility to evaluate suitability and safety of product for his own use. ACO Polymer Products Inc. reserves the right to change the product and specifications without notice.